

NPN SILICON EPITAXIAL TRANSISTOR

... designed for high voltage switching using in horizontal deflection output stage.

MAXIMUM RATINGS (T_c= 25 °C)

Characteristic	Symbol	Value	Unit
Collector Base Voltage	V _{CBO}	400	V
Collector Emitter Voltage	V _{CEO}	200	V
Emitter Base Voltage	V _{EBO}	6	V
Collector Current (DC)	I _c	7	A
Collector Current (Pulse)	I _{CP}	10	A
Base Current	I _B	4	A
Collector Power Dissipation	P _c	60	W
Junction Temperature	T _j	150	°C
Storage Temperature Range	T _{stg}	-55 ~ 150	°C

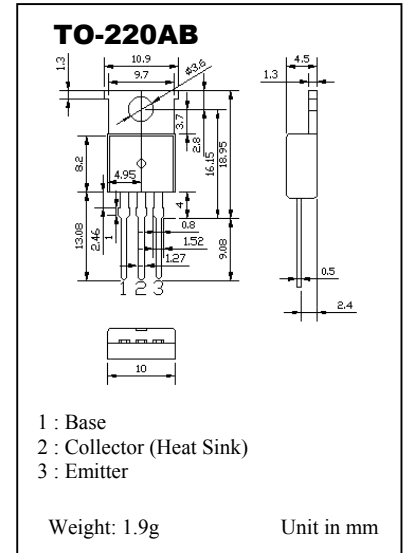

ELECTRICAL CHARACTERISTICS (T_c= 25 °C)

Characteristic	Symbol	Test Condition	Min.	Typ.	Max.	Unit
Collector Cutoff Current	I _{CES}	V _{CE} =400V, V _{BE} =0	-	-	5	mA
		V _{CE} =250V, V _{BE} =0	-	-	100	μA
		V _{CE} =250V, V _{BE} =0, T _c =150°C	-	-	1	mA
Emitter Cutoff Current	I _{EBO}	V _{BE} =6V, I _c =0	-	-	1	mA
Collector Emitter Saturation Voltage	V _{CE(sat)}	I _B =1.2A, I _c =6A	-	-	1	V
Base Emitter Saturation Voltage	V _{BE(sat)}	I _B =1.2A, I _c =6A	-	-	1.5	V
Transition Frequency	f _T	V _{CE} =10V, I _c =0.5A	10	-	-	MHz
Turn Off Time	t _{off}	I _B =1.2A, I _c =6A	-	-	0.4	μs

NPN SILICON EPITAXIAL TRANSISTOR

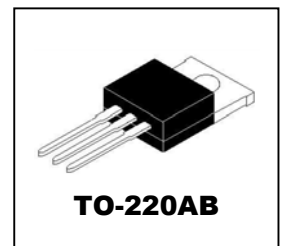

PMC reserves the right to make changes without further notice to any products herein. **PMC** makes no warranty, representation or guarantee regarding the suitability of its products for any particular purpose, nor does **PMC** assume any liability arising out of the application or use of any product or circuit, and specifically disclaims any and all liability, including without limitation consequential damages. The examples of applied circuits are provided as reference to the reader therefore we shall not undertake any responsibility for the exercise of rights by third parties.